



Rolls-Royce

Powering a better world: Rolls-Royce and the environment

**Tony Davis
CEO Rolls-Royce Australasia**

**RAeS New Zealand Division
Sustainable Aviation Seminar, Wellington
28 March 2008**

Rolls-Royce plc



**Civil
Aerospace**



**Defence
Aerospace**



Marine



Energy



Rolls-Royce Civil Aerospace

Corporate & Regional

Civil Large Engines



Australasia and the Pacific Islands



Skywest



Alliance AIRLINES



Rolls-Royce Environmental Strategy

- **Committed strategy with three related elements:**
 - maintain drive to reduce environmental impact
 - further reduce environmental impact of products
 - develop new low emission & renewable energy products
- **Annual public domain reports:**
www.Rolls-Royce/community/environment
- **Investment in reducing environmental impact**
 - About NZD \$1.8 Billion per annum
- **Global research network**
- **Working together for the whole industry**

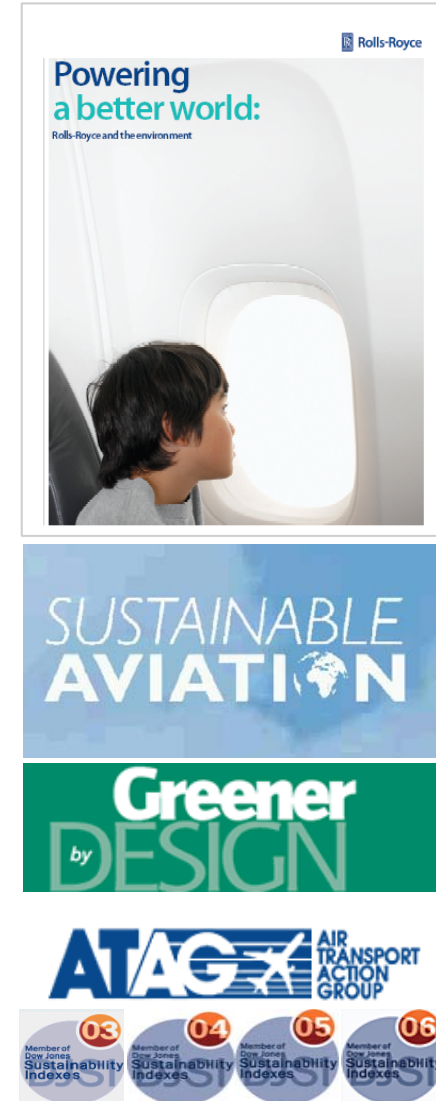

Rolls-Royce Technology 'Vision'

● Vision20 – Future generation

- Technologies that are currently emerging or as yet unproven
- Synthetic & Alternative fuels
- Targets for aircraft, engines and systems

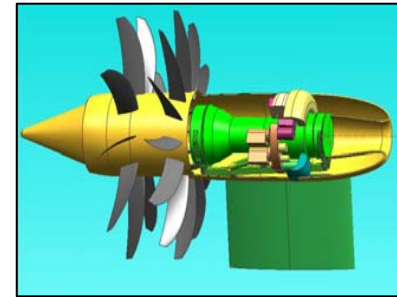
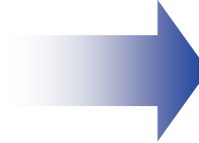

● Vision10 – Next generation

- Leading edge, technology validation
- Synthetic & Alternative fuels
- Technologies at demonstration stage

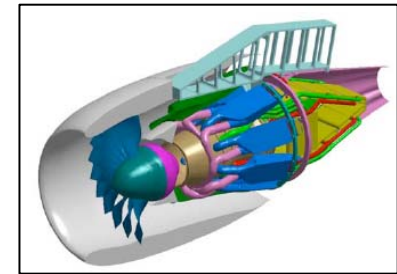

● Vision5 – Near term

- Latest 'on-the-shelf' technologies applied to existing architectures
- Near term upgrade and improvement programmes



Trent 1000
Trent XWB

Key technology programs

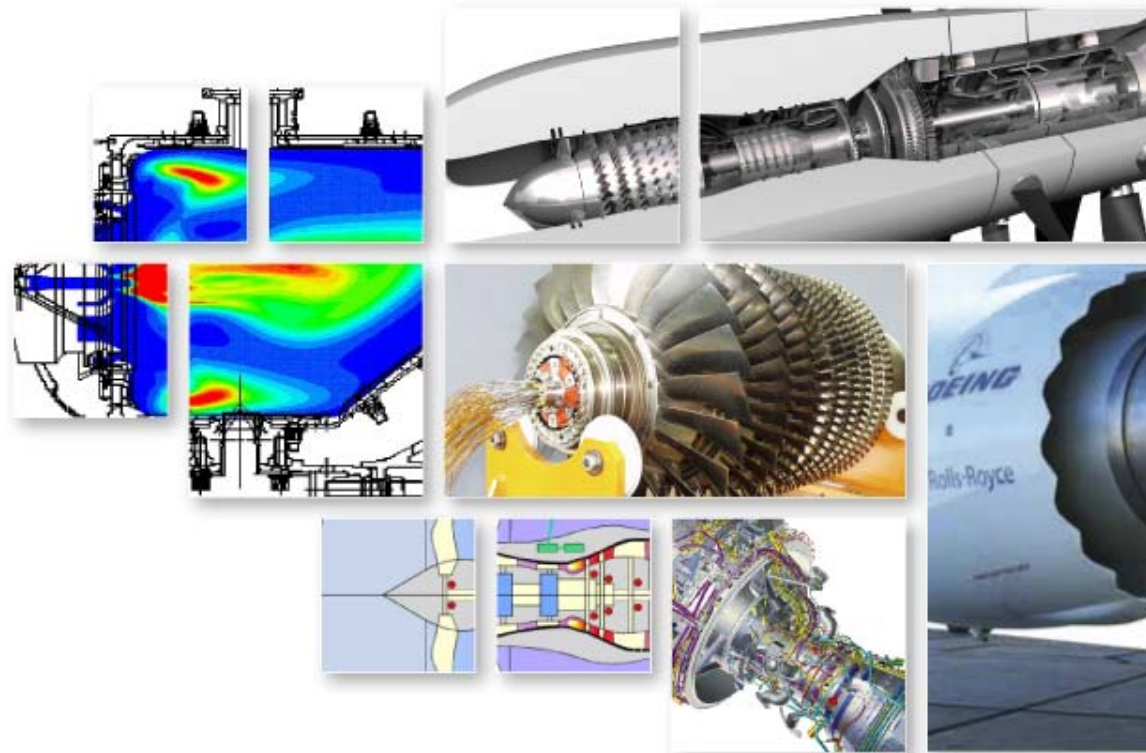

ANTLE

SILENCER
- EU programme

Power Optimised
Aircraft

E3E HP system

Environmentally
Friendly Engine

Clean Skies Joint
Technology Initiative

Vcom 14702

Vision Technology Research: Environmentally Friendly Engine (EFE)

- 5 year, NZD \$240m programme
 - Trent family donor hardware
 - Six builds, first run 2008
- Focused technology validation:
 - HP turbine (materials, cooling, aero)
 - operating at turbine entry temperatures over 200 °C hotter than today 's engines
 - delivering turbine efficiency >90%
 - Lean-burn combustion
- Programme identified as opportunity to run back-to-back tests with several alternative fuels on latest technology hardware

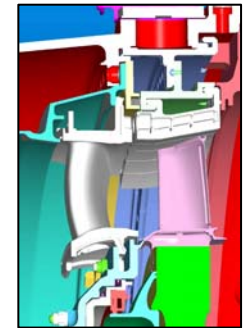
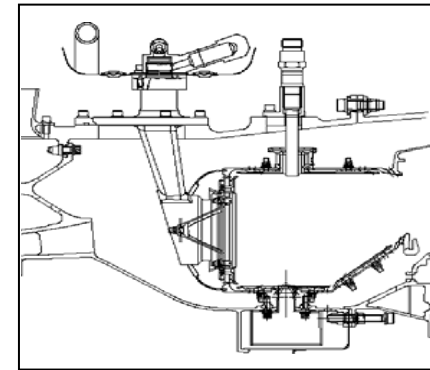
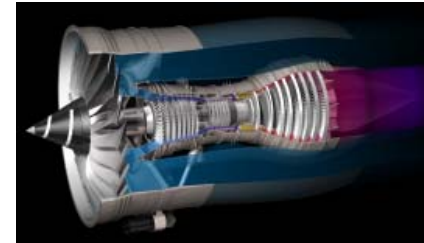

Rolls-Royce progress to future goals

- **Targets based on ACARE* cf 2000**
- **Reduce CO2 by 50% per pax km:**
 - **20% from engines**
 - **20% from airframes**
 - **10% from Air Traffic management**
- **Reduce NOx by 80%**
- **Reduce perceived average noise levels by 50%**
- **7 years into 20-year program and on-target to achieve goals**



* **Advisory Council for Aeronautics
Research in Europe**

Rolls-Royce progress to global green targets

Fuel burn (CO₂) reduction

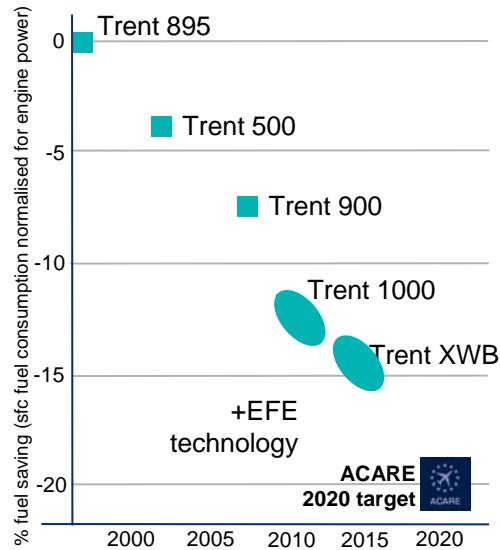

NOx reduction

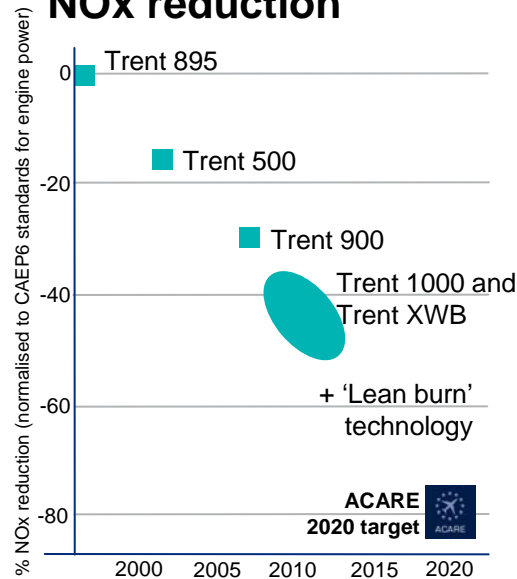

Noise reduction

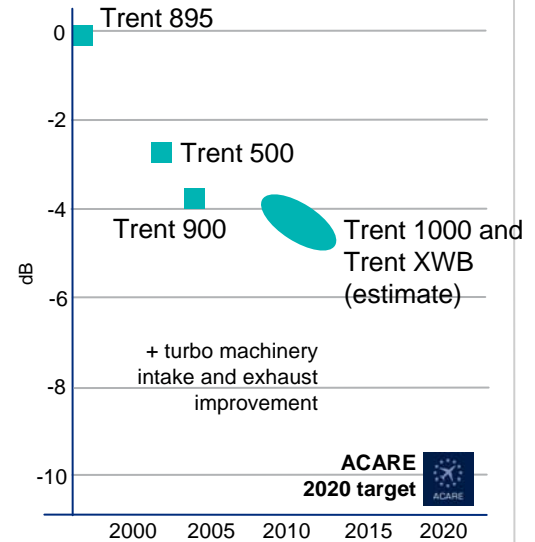

Reducing fuel consumption

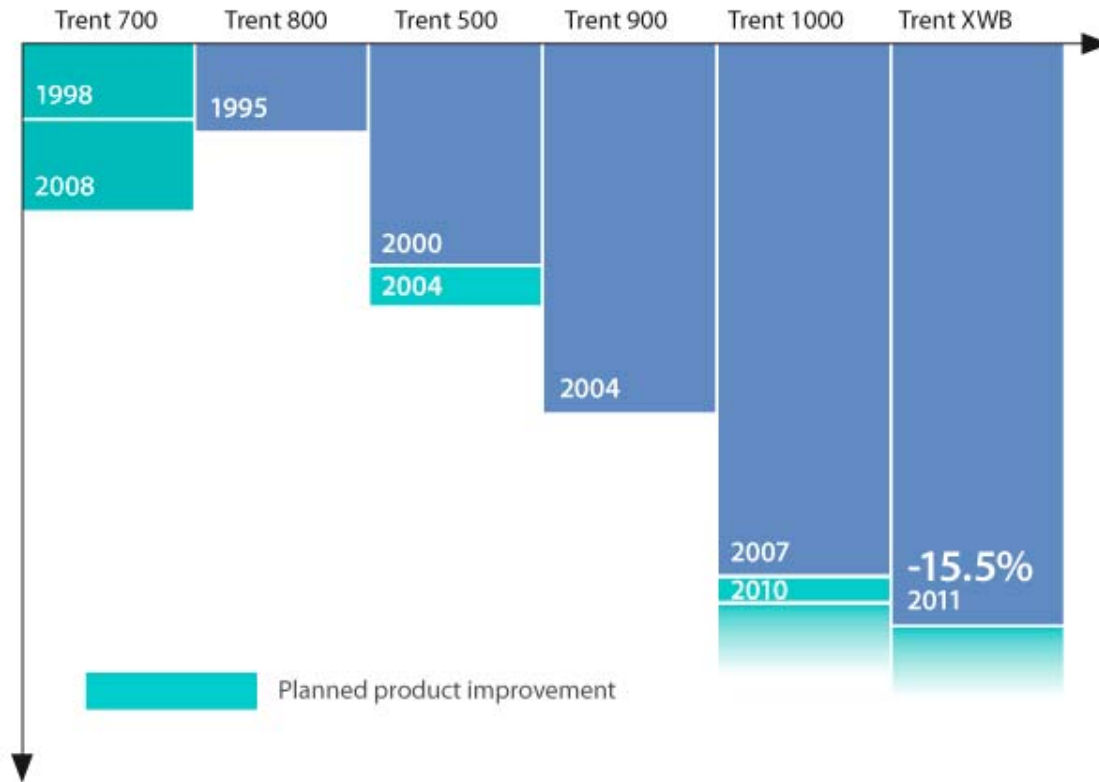

07/08/07 in Seattle...Trent 1000



Launch engine for all models of the 787

000059 11

Trent 1000 on the Boeing 787

Cycle and components designed for high efficiency, low noise and minimum environmental impact

Ribbed titanium
fancase
Lightweight / strong

3D aero compressors
More efficient

Low emissions combustor
Clean environment

Advanced turbine blades
More efficient

Advanced
materials and
coatings
*Lightweight /
long life*

HP spool contra-rotation
Lighter / more efficient

IP shaft power offtake
Unique to Trent engines

Hollow titanium fan
Lightweight / efficient

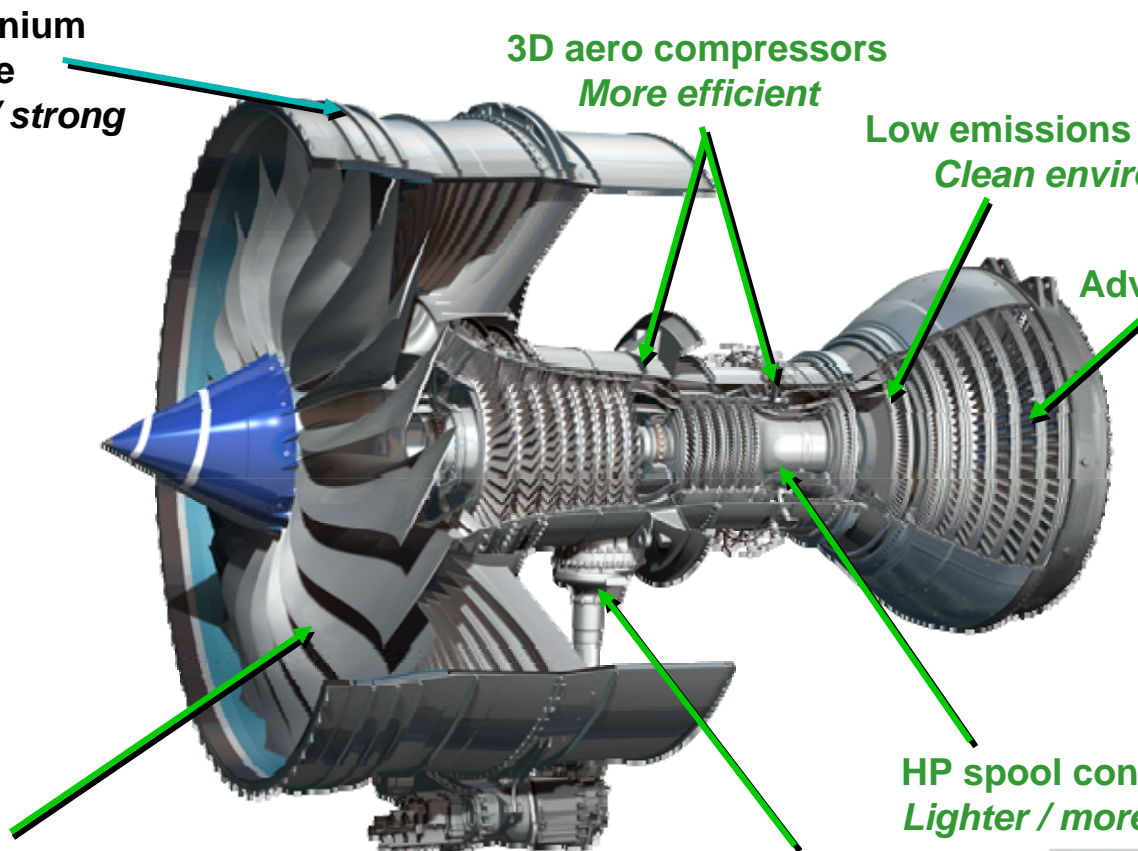



Environmentally friendly & economical

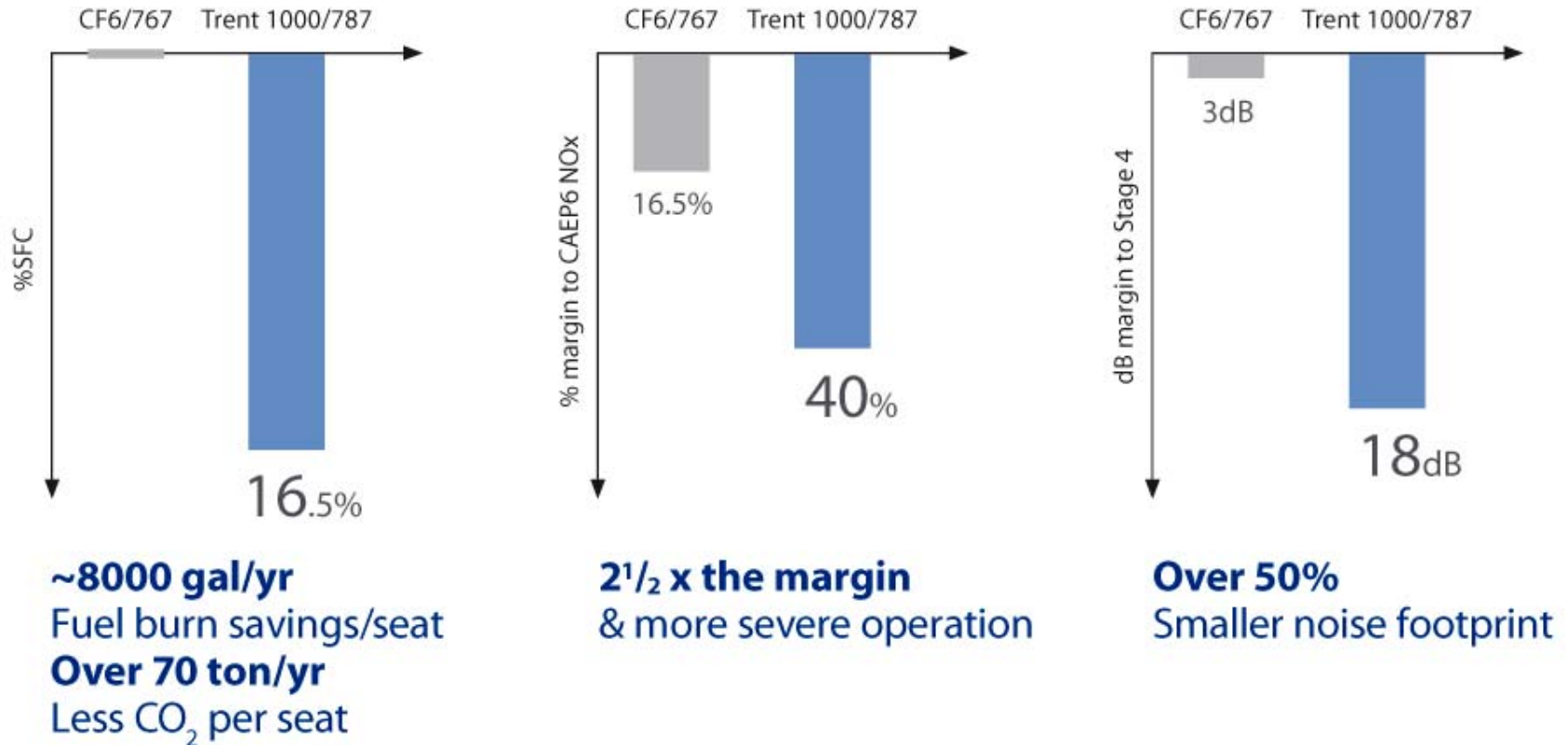

Creating a cleaner, quieter world

000049 11

Evolutionary and revolutionary

Trent experience

+

Vision technology

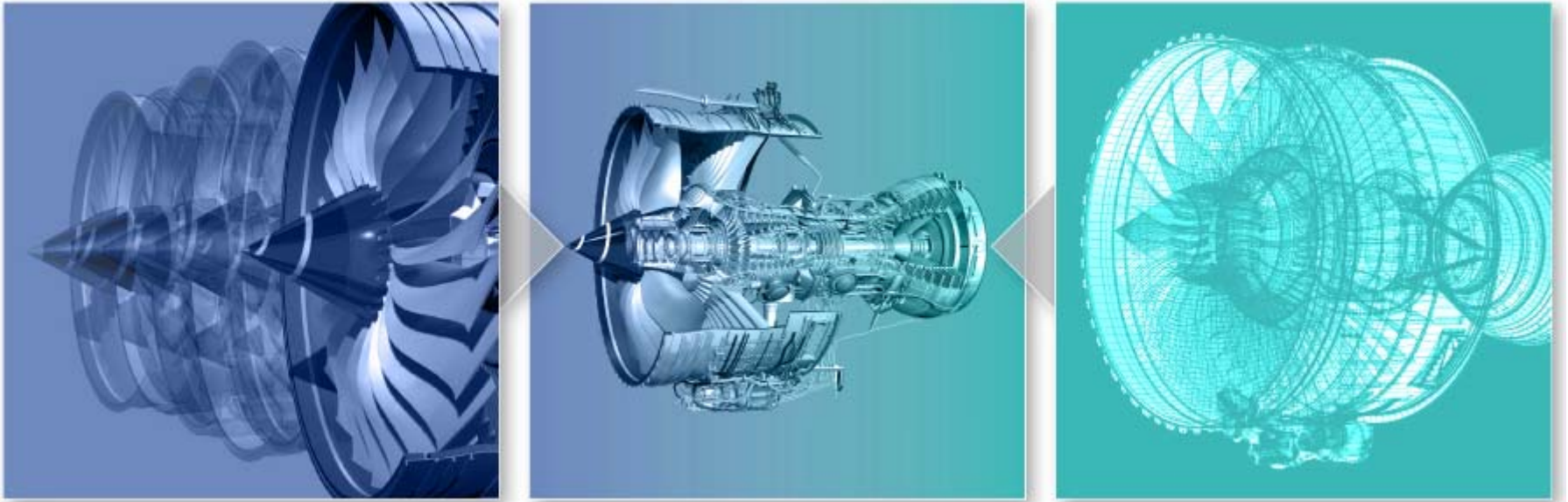

Intelligent innovation

Alternative fuels

- **Safety, energy density, low freezing point - critical for aviation fuel**
- **Currently main drivers for alternative fuels are CO2 reduction and diversity/security of supply**
- **Need to consider the total carbon life cycle and non-CO2 based emissions**
- **Potential alternative fuels:**
 - **Synthetic Fuel - aviation kerosene from Fisher-Tropsch synthesis**
 - **Bio-Fuels - Hydrogenated oils**
 - **Bio-Fuels - kerosene plus bio-derived Fatty Acid Methyl Esters**
- **Rolls-Royce is an active partner into alternative fuel research with airlines, aircraft manufacturers and fuel companies**

Airbus, Rolls-Royce & Shell A380 demo

- Flight evaluation of a 40% GTL kerosene fuel blended with conventional fuel
- Part of research programme to understand renewable fuels and potential future applications.
 - Aircraft - Airbus A380 MSN4
 - Engine - one Trent 900 engine powered using the derived fuel
 - Test Date - 1 Feb 2008
- Data gathered throughout the test process will contribute to understanding of the capabilities and limitations of renewable synthetic fuels



Air New Zealand, Boeing & Rolls-Royce Renewable Fuels Study Program

- Flight evaluation of a renewable bio fuel blended with kerosene fuel source
- Part of research programme to understand renewable fuels and potential future applications.
 - Aircraft - Air New Zealand Boeing 747-400
 - Engine - only one RB211-524 engine will use the derived fuel
 - Timing - Second half of 2008 depending on availability of fuel
- Data gathered throughout the test process will contribute to understanding of the capabilities and limitations of renewable fuels



Summary

Rolls-Royce:

- **is committed to helping society address the problem of climate change**
- **has a proven environmental track record with our products**
- **is committed to a strategy of continuous improvement**
- **invests in advanced technologies and programs focussed on reducing environmental impact**
- **is at the forefront of understanding and addressing aviation environmental issues**
- **is determined to be an active part of the solution to the environmental challenge**

 Rolls-Royce

Powering a better world:

Rolls-Royce and the environment



Rolls-Royce

Questions?